



Rigging and Assembly Instructions



ESW CLOSED CIRCUIT COOLERS

FOR EVAPCO AUTHORIZED PARTS AND SERVICE, CONTACT YOUR LOCAL
MR. GOODTOWER SERVICE PROVIDER OR THE EVAPCO PLANT NEAREST YOU.

EVAPCO products are manufactured worldwide:

EVAPCO, INC. (World Headquarters) P.O. Box 1300, Westminster, Maryland 21158 USA
Phone (410) 756-2600 Fax (410) 756-6450

EVAPCO Europe

Industrieterrein Oost 4010
3700 Tongeren, Belgium
Phone: (32) 12 395029
Fax: (32) 12 238527
Email: evapco.europe@evapco.be

EVAPCO Europe S.r.l.

Via Ciro Menotti 10
20017 Passirana di Rho (MI), Italy
Phone: (39) 02 9399041
Fax: (39) 02 93500840
Email: evapcoeuropa@evapco.it

EVAPCO Europe GmbH

Bovert 22
D-40670 Meerbusch, Germany
Phone: (49) 2159-6956-0
Fax: (49) 2159-6956-11
Email: info@evapco.de

ESW Closed Circuit Coolers

Method of Shipment

ESW models are shipped with the top section(s) separate from the bottom section(s). These sections have mating flanges and will join together in a waterproof joint when sealed and bolted together as described in the following instructions. Miscellaneous items, such as sealer tape, bolt sets and any other required materials, are packaged and placed inside the pan for shipment.

Storage

Do not place tarps or other coverings over the top of the units if the units are to be stored before installation. Excessive heat can build up if the units are covered, causing possible damage to the PVC eliminators, PVC louvers, or PVC fill. For extended storage beyond six months, rotate the fan and fan motor shaft(s) monthly. Also, the fan shaft bearings should be purged and regreased prior to start-up.

Structural Steel Support

Two structural "I" beams running the length of the unit are all that is required for support of the units. These beams should be located underneath the outer flanges of the unit (see Figure 1). Mounting holes, 19 mm in diameter, are located in the bottom flange of the unit to provide for bolting it to the structural steel (see certified print for exact bolt hole location). Bolt the bottom section to the steel support before rigging the top section.

Beams should be sized in accordance with accepted structural practices. Maximum deflection of the beam under the unit to be 1/360 of the unit length, not to exceed 13 mm. Deflection may be calculated by using 55% of the operating weight as a uniform load on each beam (see certified print for operating weight).

The supporting "I" beams should be level before setting the unit. Do not level the unit by shimming between the bottom flange and the beams as this will not provide proper longitudinal support.

Support beams and anchor bolts are to be furnished by others. Always refer to certified print for unit weights, dimensions and technical data.

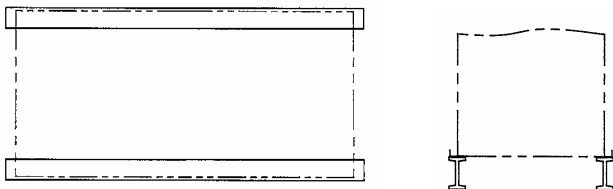

Figure 1 - Structural Steel Support.

Rigging Bottom Section

Lifting devices are located in the upper corners of the coil as shown in Figure 2. The hook of the crane must be a minimum dimension of "H" above the top of the coil to prevent undue strain on the lifting devices.

See Table 1 for the minimum "H" dimension. These lifting devices should not be used for extended lifts or where any hazard exists unless safety slings are employed under the section. **(See "Extended Lifts" on page 4 for proper arrangement.)** Bolt the bottom section to the steel support before rigging the top section.

Basin Section Length - m	MIN. H (Above Coil) - m
2,7	2,1
3,6	3,0
5,4	4,2

Table 1 - Minimum H Dimension for Bottom Sections.

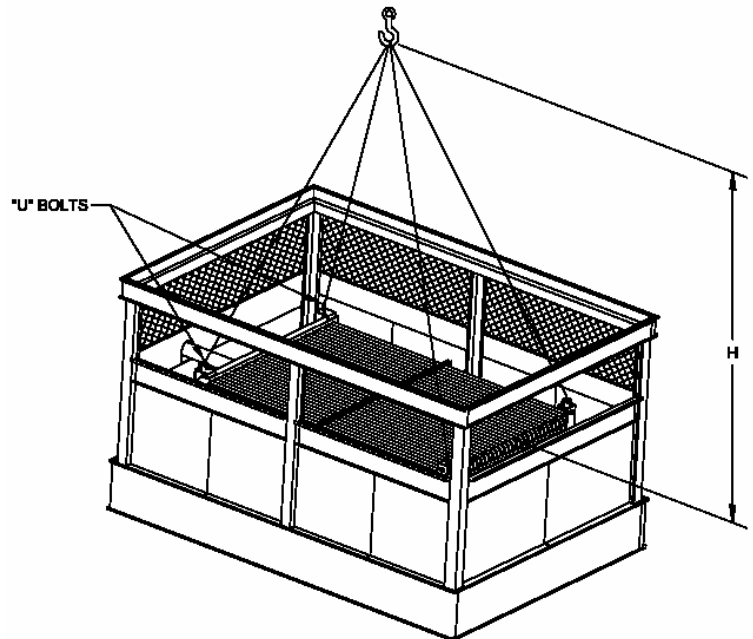

Figure 2 - ESW Bottom Section

ESW Closed Circuit Coolers

Applying Sealer Tape

Once the bottom section has been set on the supporting steel and bolted in place, the top flanges should be wiped down to remove any dirt or moisture. Sealer tape should be placed over the mounting hole centerline on the side flanges. Apply two strips of sealer tape, one partially overlapping the other, on the end flanges.

The sealer tape should overlap on the corners as shown in Figure 3. Do not splice the sealer tape along the end flanges and preferably not on the side flanges if it can be avoided. Always remove the paper backing from the sealer tape.

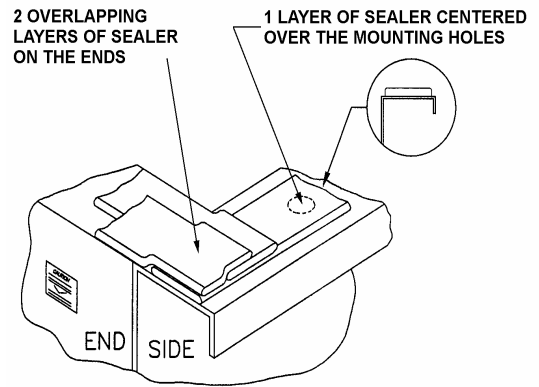

Figure 3 - Proper Sealer Tape Application

Top Section

“U” bolts are provided in the four corners of the top section for lifting and final positioning (See Figure 4). The hook of the crane must be a minimum dimension “H” above the top section being lifted to prevent undue strain on the “U” bolts. See Table 2 for the minimum “H” dimension.

UNIT NO.	MIN. H - m
ESW 72 models	2,7
ESW 96 models	3,6
ESW 142 models	5,1
ESW 144 models	3,6
ESW 216 models	5,1

Table 2 -Minimum H Dimension for Top Sections.

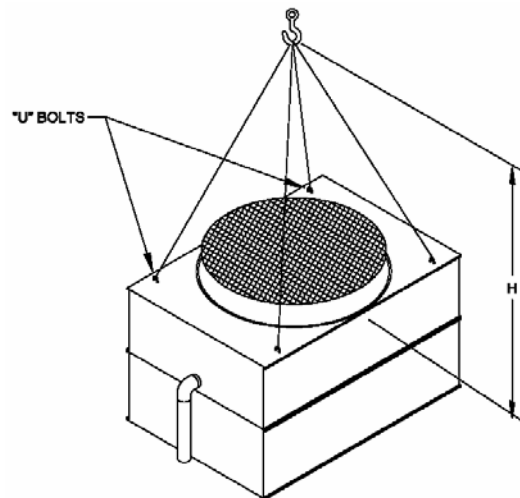

Figure 4 - ESW Top Section.

Assembly of the Top Section to the Bottom Section

Before assembling the top section to the bottom section, remove any loose parts shipped in the pan.

Wipe the flanges on the bottom of the top section. Check to see that the water distribution connection on the top section is in the correct position relative to the bottom section (see certified unit drawing). Units are also provided with match markings on each section (i.e. A1 of bottom section should match up with A1 of top section).

Lower the top section to within several inches of the bottom section making sure the two sections do not touch and the sealer is not disturbed. Using suitably sized drift pins to assure proper alignment, lower the top section down onto the bottom section. Fasten all four corners. Install the remaining fasteners, working from the corners toward the center, using drift pins to align the holes. Fasteners must be installed in every hole on the side flange. None are required on the end flanges. Galvanized units will use 5/16” self tapping screws and stainless steel units will use 8 mm nuts, bolts and washers. See Figure 5.

Note: 8 mm stainless steel nuts, bolts and washers are used on stainless steel models.

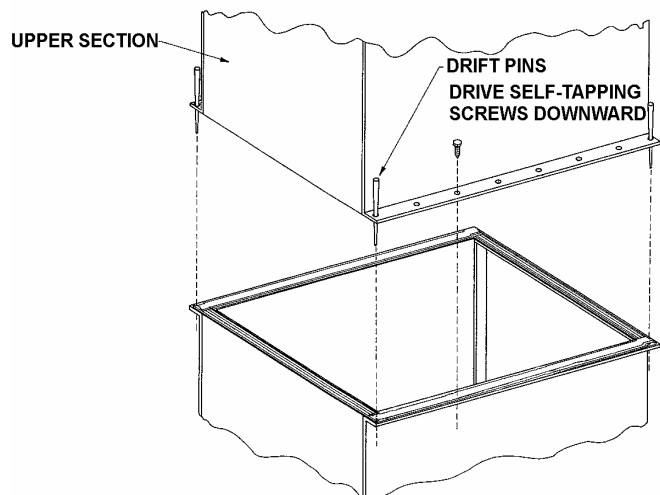

Figure 5 - Mating Upper Section to Bottom Section.

ESW Closed Circuit Coolers

Extended Lifts

Important: The lifting devices and “U” bolts should be used for final positioning only and for lifting where no danger exists. If they are used for extended lifts, safety slings should be provided under the sections.

The preferred method for extended lifts is to use slings under the unit (see Figures 5, 6, 7). Spreader bars should always be used between the cables at the top of the section to prevent damage to the upper flanges or fan cylinders.

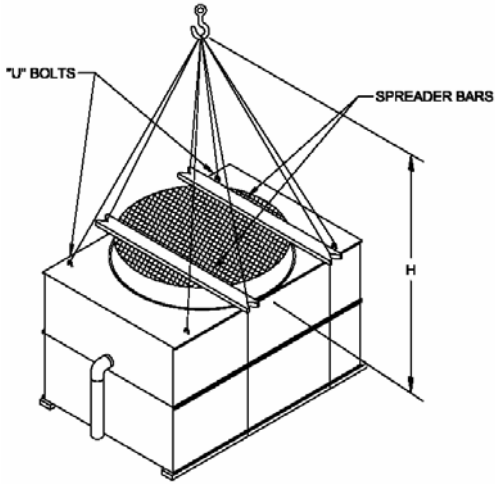

Figure 6 -ESW Top Section

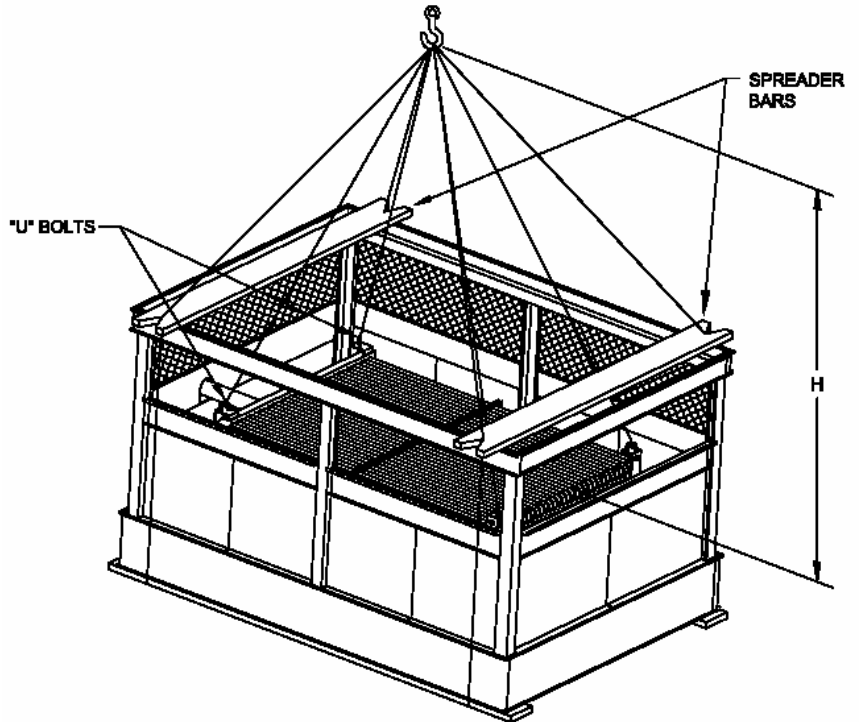

Figure 7 - Proper Rigging Method for Extended Lifts. (2,7 & 3,6 m long units)

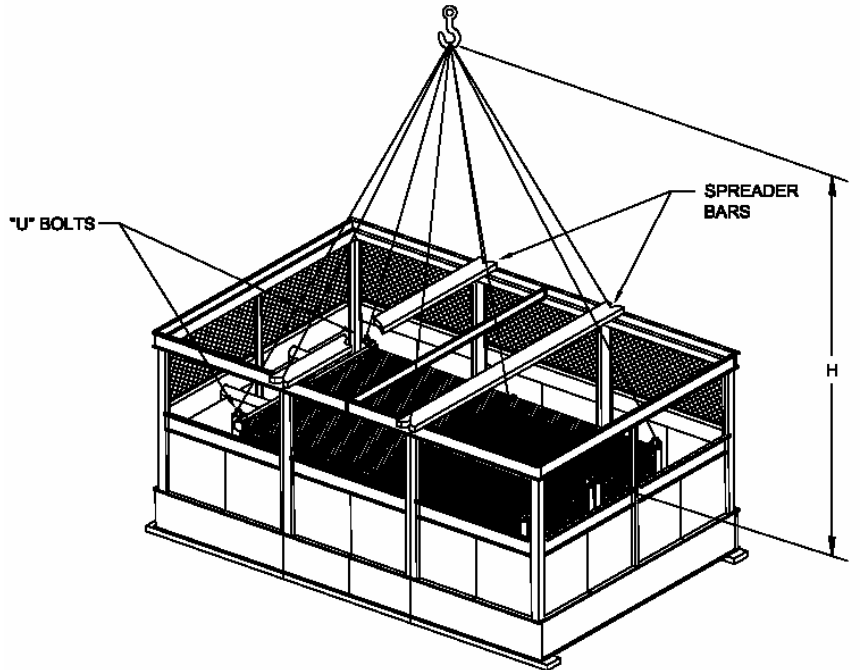

Figure 8 - Proper Rigging Method for Extended Lifts. (5,4 m long units)

Safety slings and skids should be removed before final positioning of the unit.

ESW Closed Circuit Coolers

Mounting Fan Screens 3,6 m Wide Models

In certain situations some units may be shipped with the fan screens in the basin. Under these circumstances, use the following procedures to mount the fan screen on the discharge cylinder.

WARNING: DO NOT WALK ON THE FAN SCREENS AT ANY TIME!

1. Place both halves of the fan screen on top of the discharge cylinder. Each half will be tagged to match markings on the cylinder. Align the eyelets of the fan screen with the holes that can be found on the perimeter of the discharge cylinder.
2. At each hole, attach the fan screen to the discharge cylinder as shown in Figure 9.
3. Join the two screen halves with wire clips (Figure 10).

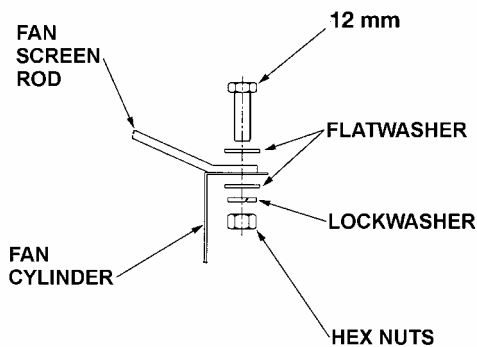

Figure 9 - Attaching Fan Screen to Cylinder

There should be 3 wire clips on each side of the fan screen. Space the wire clips evenly across the radius of the fan screen as shown in Figure 11.

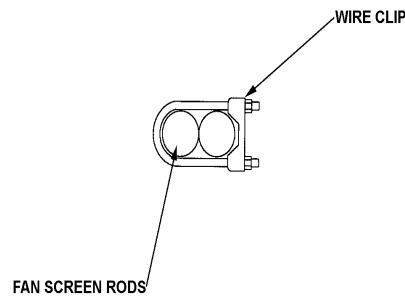

Figure 10 - Wire Clip Arrangement

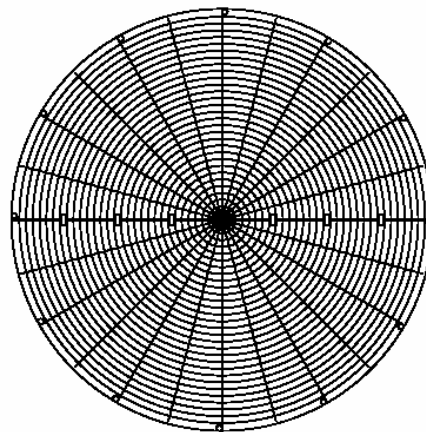

Figure 11- Wire Clip Spacing

Mounting Fan Screens 3,6 m Wide by 5,4 m Long Models

On these models, the fan screen is supported from underneath by an "X" shaped support frame.

1. Set the support frame across the top of the discharge cylinder (See Figure 12).
2. Place both halves of the fan screen on top of the support frame. Each half will be tagged to match markings on the cylinder. Align the eyelets of the fan screen with the holes on the cylinder perimeter.
3. Join the two screen halves with wire clips (See Figure 10). There should be four clips on either side of the fan screen. Space them evenly as shown in Figure 11.
4. At each hole, attach the fan screen to the discharge cylinder as shown in Figure 9. At the four points where the support frame meets the cylinder, bolt the support frame to the cylinder together with the fan screen.

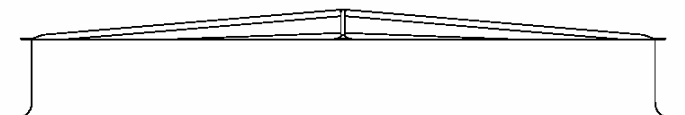

Figure 12 - Support Frame Installation

ESW Closed Circuit Coolers

Optional Motor and Gear Box Davit

This accessory is available to aid in the removal of fan motors and gear boxes. The assembly consists of a davit and a mounting base that is attached to the side of the unit next to the access door. Both of these items will ship loose in the unit's basin. There are two types of motor davits: single point davits provided on units with the Powerband Belt Drive System (Figure 12) and dual point davits provided on units with the optional gear drive system (Figure 13). Use the following procedure to install the mounting base.

1. Place the mounting base on the 8 mm studs protruding from the fan section near the access door.
2. Use 8 mm lockwashers and nuts to secure the mounting base to the unit (See Figure 14).

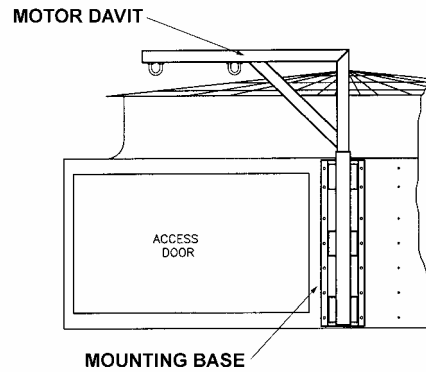

Figure 13 - Dual Point Davit Arrangement

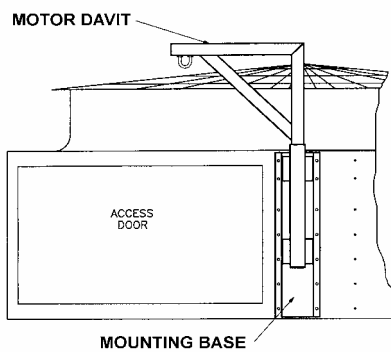

Figure 12 - Single Point Davit Arrangement

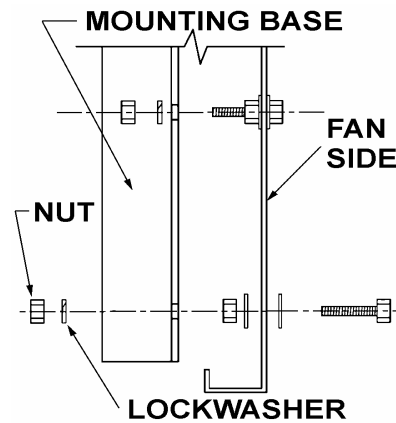

Figure 14 - Mounting Base Installation

General Information - Start-up & Maintenance

Rigging Hardware Parts List

The following table lists those parts which are shipped together with the unit(s) for field assembly and/or spare parts.

ESW Model	Box Size (m)	Self Tappers ¹	Sealer Tape	Nozzles
ESW 72 Models	2,4 x 2,7	45	4	2
ESW 96 Models	2,4 x 3,6	60	5	2
ESW 142 Models	2,4 x 5,4	90	5	2
ESW 144 Models	3,6 x 3,6	60	5	2
ESW 216 Models	3,6 x 5,4	90	6	3

Notes:

1. 5/16 x 1" Tapper. Stainless units use 8 mm nuts and bolts.

Table 5 – Rigging Hardware

ESW Closed Circuit Coolers

External Motor Installation 2,4 m Wide Models

1. Study Figure 15 before installing the motor base on the unit.
2. Insert the lifting device into "U" bolt **A** on motor base **B**.
3. Lift the motor base and insert the pivot pin **C** down into hole **E** and pivot pin **F** into hole **D**.
4. Install washer and nut (do not overtighten) on pivot pins. Install jam nut on pivot pin **C**.
5. Insert "J" bolts **G** into holes **H**. Install flat washers and cotter pins. Place nuts and washers on threaded portion of "J" bolts. These will be behind the motor base installed in the next step.
6. Insert "J" bolts into holes **J** in the motor base. Install flat washers, lock washer and nuts. Remove lifting device from the "U" bolt on the motor base. Position motor base toward casing of unit for belt installation.
7. Install Powerband belt **K** (Figure 16) around fan sheave and otor sheave. Tighten belt by adjusting nuts on "J" bolts. Do not over tighten the belts. The center of the belt should deflect approximately 19 mm with moderate hand pressure.
8. Measure to see that the top and bottom of the motor base are the same distance out from the casing of the unit. This should ensure that the sheaves are properly aligned as they have been pre-set at the factory.
9. As a final check, lay a straight edge from sheave to sheave. There should be four point contact. (See Figure 17.) Adjust the position of the motor sheave as necessary.
10. To install Motor Guard **L**, match up hinges and install hinge pins **M**. (See Figure 16.)
11. Close Motor Guard and install (2) wing bolts **N**.

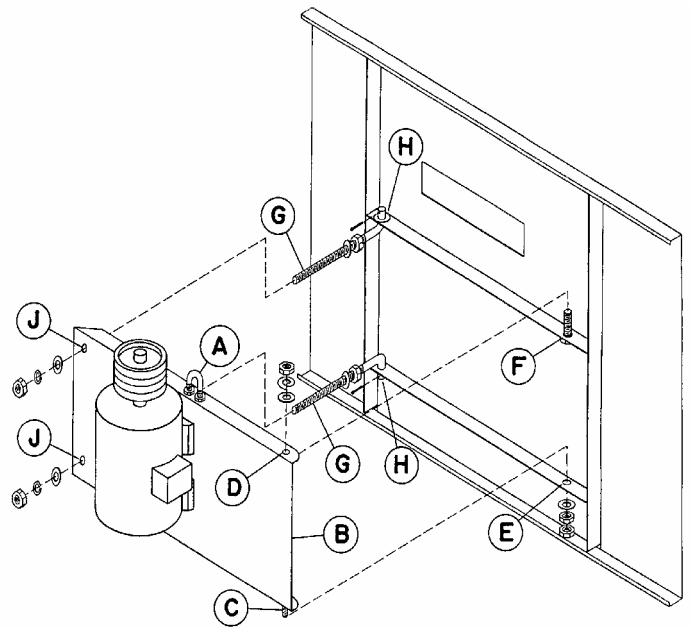

Figure 15 - External Motor Installation

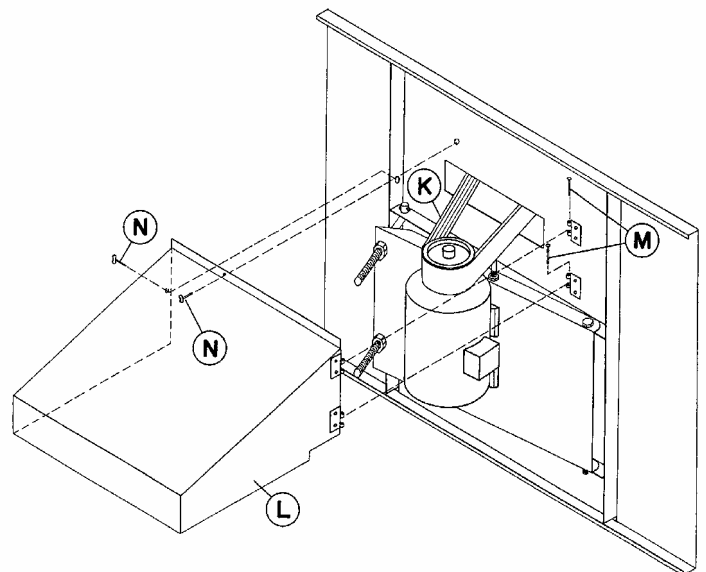

Figure 16 - Motor Guard and Powerband Belt Installation

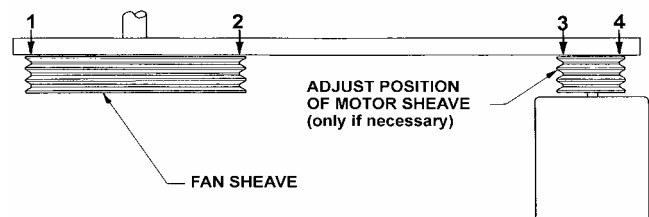

Figure 17 - Sheave Alignment Check

ESW Closed Circuit Coolers

Start-up Details Shipping Chocks and Debris

Remove any chocks that have been placed inside the unit for shipping purposes. Be sure to remove the chocks from between the fan and fan guard if applicable. Clean all debris from the basin prior to start-up. Close and secure all access doors.

Pump Discharge Line

Connect the riser pipe from the pump discharge on the basin section to the riser pipe on the coil/fan section using the flexible connection and hose clamps provided.

Bleed-off Line

A bleed-off line and valve are installed on the unit when shipped with a pump. On units shipped without a pump (remote sump applications) make sure a bleed-off line and valve are properly sized and installed on the discharge side of the pump and connected to a convenient drain. In either case, the bleed-off valve should be fully open.

Strainer

Check the strainers, if applicable, in the basin section to make certain they are in the proper location over the pump suction, along side of the anti-vortex hood. (See Figure 17.)

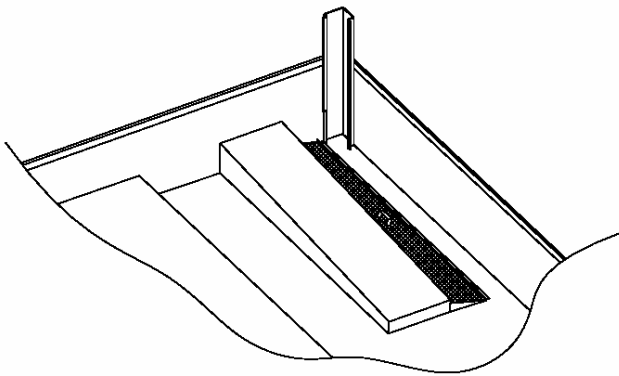

Figure 18 - Strainer Location

Screens

Protective fan screens are provided across the top of the fan cylinders of all models. Check and tighten all bolts.

Float Valve Adjustment

The float valve is pre-set at the factory; however, adjustment should be checked after rigging. The float valve should be adjusted so that the centerline of the float is at the measurement shown in Table 3 from the basin bottom. Raise or lower the float by using the wing nuts on the vertical threaded rod only. Do not adjust the horizontal rod.

Unit Length	Level (mm)
All Models	340

Table 3– Recommended Water Level

Starting Sequence

Before starting the unit, check that all access openings, safety screens and covers are in place. Start the unit as outlined below:

1. Fill the pan to the overflow level.
2. Bump start and check the spray water pump(s) for proper rotation. Directional arrows are found on the pump impeller housing.
3. Bump start and check the fan(s) for proper rotation. Directional arrows are placed on the side of the fan cylinder.

Maintenance

Once the installation is complete and the unit is turned on, it is important that it be properly maintained. Maintenance is not difficult or time-consuming but must be done regularly to assure full performance of the unit. Refer to the maintenance instructions enclosed with the unit for proper maintenance procedures.

Freeze Protection

Proper freeze protection must be provided if the unit is located in a cold climate. Refer to maintenance instructions as well as product bulletins for further information.

Note: Closed circuit coolers should be used on sealed, pressurized systems. Continual aeration of the water in an open system can cause corrosion inside the tubes of the cooler, leading to premature failure.